

User manual

MANUEL D'UTILISATION
GEBRUIKSAANWIJZING
GEBRAUCHSANWEISUNG
MANUALE DI ISTRUZIONI
MANUAL DE INSTRUCCIONES
INSTRUKCJA OBSŁUGI
NÁVOD K OBSLUZE

Navix SU



Contents

Contents	1
Preface	2
1 Your product	3
1.1 Accessories	3
2 Before use	4
2.1 Intended use	4
2.2 Symbols on the wheelchair	4
2.3 General safety instructions	4
2.4 Transport	5
2.5 First use and storage	6
3 Using your wheelchair	7
3.1 First ride	7
3.2 Driving outdoors	7
3.3 Operating console	8
3.4 Brake and free-wheel lever	9
3.5 Moving to/from wheelchair	9
3.6 Comfort adjustments	10
3.7 Standing / upright function	12
3.8 Battery status and charging	13
3.9 Anti-tipping (B78)	14
4 Maintenance	15
4.1 Time of maintenance	15
4.2 Instructions for maintenance	15
4.3 Troubleshooting	16
4.4 Expected lifespan	17
4.5 Reuse	17
4.6 End of use	17
5 Technical specifications	18

Preface

Congratulations! You are now owner of a Vermeiren wheelchair!

This wheelchair is made by qualified and committed personnel. It is designed and produced according to high quality standards, guarded by Vermeiren.

Thank you for your trust in the products of Vermeiren. To support you on the use of this wheelchair and its operating options, this manual is offered. Please read it carefully; it will help you to get familiar with the operation, capabilities and limitations of your wheelchair.

If you still have questions after reading this manual, do not hesitate to contact your specialist dealer. He/she will be glad to help you.

Important note

To ensure your safety and to prolong the lifetime of your product, please take good care of it and have it checked and serviced on a regular basis.

This manual reflects the latest product developments. Vermeiren has the right to implement changes to this type of product without any obligation to adapt or replace similar products previously delivered.

Pictures of the product are used to clarify the instructions in this manual. Details of the depicted product may deviate from your product.

Information available

On our website <http://www.vermeiren.com/> you will always find the most recent version of the information in this manual. Please consult this website regularly for possible updates.

Visually impaired people can download the electronic version of this manual and have it read out by means of a text-to-speech software application.



This user manual
For user and specialist dealer



User manual of applied operating console and battery charger.
For user and specialist dealer



Installation instructions
For specialist dealer



Service manual for wheelchairs
For specialist dealer



EC declaration of conformity

1 Your product



1.1 Accessories

The following accessories are available for the electric wheelchair Navix SU:

- Table (B15+B13)
- Lighting
- Side supports

2 Before use

2.1 Intended use

In this paragraph a brief description of the intended use of your wheelchair is given. Additionally, relevant warnings are added to the instructions in the other paragraphs. In this way we would like to make you aware of the possible misuse that may appear.

- Indications and contraindications: This wheelchair is meant to be operated by the user sitting in the wheelchair. The wheelchair is designed and produced to be a transport aid for persons with walking difficulties or no walking abilities. You should NOT use this wheelchair if you suffer from physical or mental impairments that may put you, or other people, in danger when driving the wheelchair. For this reason, consult your doctor first and make sure that your specialist dealer is informed about his advice.
- This wheelchair is suitable for indoor and outdoor use.
- This wheelchair is designed and produced solely to transport/transfer one (1) person with a maximum weight of 130kg. It is not designed for transportation of goods or objects, nor for any use other than previously described.
- Only use accessories and spare parts approved by Vermeiren.
- Please read all technical details and limits of your wheelchair in chapter 5.
- The warranty on this product is based on normal use and maintenance as described in this manual. Damage to your product caused by improper use or lack of maintenance will cause the warranty to lapse.

2.2 Symbols on the wheelchair



Maximum weight of the user in kg



Indoor/outdoor use (battery charger excluded)



Indoor use only (battery charger)



Maximum safe slope in ° (degrees).



Maximum speed



Type designation



Risk of entrapment

2.3 General safety instructions

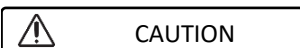

CAUTION

Risk of injuries and/or damage

Please read and follow the instructions in this manual. Otherwise you may get injured or your wheelchair may get damaged.

Keep the following general warnings in mind during use:

- Do not use your wheelchair if you are under influence of alcohol, medicines or other substances that may influence your driving abilities.
- Be aware that some parts of your wheelchair may get very hot or cold due to ambient temperature, solar radiation, heating devices or due to the motor drive during the ride. Be careful when touching. Wear protective clothing if the weather is cold. After a ride, wait until the wheelchair/motor has cooled down.
- Before switching the wheelchair on, be aware of the environment/situation in which you are located. Adjust your speed to this before driving off. We advise you to use the slowest speed setting to drive indoors. For outdoor driving you can adjust the speed to a suitable speed at which you feel comfortable and safe.
- ALWAYS keep in mind that your wheelchair may stop suddenly due to a discharged battery or a protection that prevents your wheelchair from further damage. Also check the possible causes mentioned in § 4.3. Use your safety belt to prevent injuries.
- Your wheelchair has been tested for electromagnetic compatibility and complies with the standard, see chapter 5. Nevertheless, sources of electromagnetic fields may influence the driving performance of your wheelchair, such as the fields of mobile phones, power generators or high-power energy sources. On the other hand, the electronics of your wheelchair can affect other electronic appliances too, such as alarm systems of shops and automatic doors. We therefore advise you to check your wheelchair regularly for damage and wear, since these may enlarge the interference (see also chapter 4).
- Only drive on flat surfaces where both driving wheels touch the ground and where there is sufficient contact to operate the wheelchair safely.
- Alterations or substitutions should not be made to the wheelchair securement points or to structural and frame parts or components without consulting the wheelchair manufacturer.
- Make sure that your hands, clothes, belts, buckles or jewellery don't get caught by wheels or other moving parts during use.

Be aware that your wheelchair may interfere with some types of anti-theft systems, depending on the settings used. This may cause the shop's alarm to go off.

In case a serious incident has occurred involving your product, notify Vermeiren or your specialist dealer as well as the competent authority in your country.

2.4 Transport

CAUTION

Risk of damage

Take action to protect the wheelchair from being damaged during transport.

2.4.1 Moving out of the way

Use the operating console to drive the wheelchair to its destination.

Otherwise, put the wheelchair in free-wheel mode (see §3.4) and use the push bar to move it.

2.4.2 Transport by aircraft

Since the wheelchair is equipped with non-spillable AGM batteries, it is possible to transport the wheelchair (as a whole) by aircraft. Consult your airline for the correct handling procedures before booking your flight. Before handing your wheelchair over to the airport personnel, disconnect the battery from the wheelchair, see installation manual.

2.4.3 Transport by vehicle, as luggage



WARNING

Risk of injuries

- Do NOT use your wheelchair as seat in a vehicle, see the following symbol.
- Never use the same safety belt for passenger and wheelchair.



The best way to transport your electric wheelchair in the car is to drive it by using ramps. If you are not experienced to drive the electric wheelchair using ramps, you can put the wheelchair in neutral mode and push the wheelchair in the car using ramps. If necessary, disassemble the wheelchair.

1. As the wheelchair user, transfer to a car seat, see §3.5.
2. Remove all moveable parts prior to transport.
3. Store moveable parts safely behind the passenger seat or in the luggage compartment.
4. Drive or push the electric wheelchair in the car using ramps, or lift the wheelchair in the car with the help of 2 persons by grasping the fixed parts of the frames.
5. Attach the solid parts of the frame securely to the vehicle (see illustration).
6. Place the wheelchair in drive mode (engaging the parking brakes) and check that the operating console is switched off.

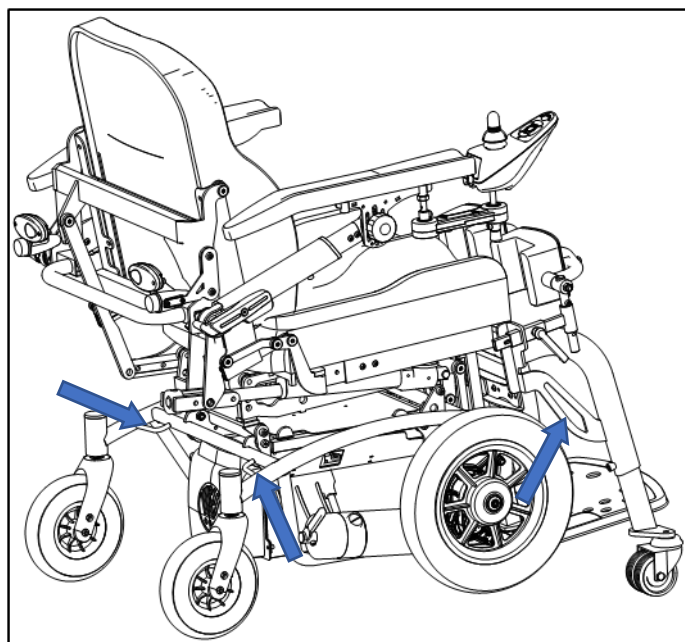

2.5 First use and storage



CAUTION

Risk of battery damage

- Never completely discharge the battery.
- Do not interrupt the charging cycle; only disconnect the battery charger when the battery is fully charged.
- Make sure that your wheelchair is stored dry to prevent mould from growing and the upholstery from being damaged.
- Check the technical details for storage, see chapter 5.

Ensure that the battery has been fully charged before using your wheelchair, ask your dealer if this has already been done or not. To charge, follow the charging instructions in §3.8.

3 Using your wheelchair



WARNING

Risk of injuries

- First read previous chapters and inform yourself about the intended use. Do NOT use your wheelchair unless you have read and fully understood all instructions.
- Also read the instructions in the operator console manual and battery charger manual!
- In case of doubts or questions, do not hesitate to contact your local specialist dealer, your care provider or technical adviser to help you with this.

3.1 First ride



CAUTION

Risk of injuries and damage

- Always keep the swing range of footrest and operating console in mind to prevent bystanders from being injured or objects from being damaged.
 - Always unplug the battery charger from the wheelchair before starting to drive.
- i**
- Make sure that you are familiar with the operation of your wheelchair before using it in crowded and possibly dangerous places. First exercise at a spacious, open area with little bystanders.
 - Investigate the effects of shifting the centre of gravity on the behaviour of the wheelchair, for example on up or down gradients, on laterally sloping ground, or when overcoming obstacles. Obtain support from an attendant.
 - The surface of the controller gets slightly warm during use.
 - While driving backwards, the speed is reduced.
1. Make sure that:
 - the wheelchair is on a flat surface;
 - the battery is fully loaded, see §3.8;
 - The motor is coupled, see § 3.4;
 - the tyres have the correct tyre pressure, see § 4.2.1;
 - the wheelchair is adapted to your needs and comfort, see §3.6;
 - you have the proper sitting position, see § 3.5.
 2. Follow the instructions in the operating console manual.
 3. Switch on your wheelchair.
 4. Turn the speed control to the lowest speed setting.
 5. Exercise how to drive and make adjustments to the wheelchair.
 6. If you feel confident enough, you can try to drive at higher speed.
 7. Now try to turn, in forward and backward direction. Repeat this a few times.
 8. Make sure that your wheelchair stands stable, when ending the ride.
 9. Switch off your wheelchair.

3.2 Driving outdoors



WARNING

Risk of accident - Adjust your driving behaviour and speed.

- Take the local road traffic law into consideration; it may differ per country. This counts for driving on pavements, unpaved roads or paved roadways.
- Do not drive on roads with heavy traffic.
- Take the weather conditions into consideration. Avoid driving by moist weather, extreme heat, snow, black ice, freezing temperatures; see technical specifications in chapter 5.
- The wheelchair is not suitable to drive on public roads at poor visibility (darkness, mist, twilight). Make sure that you are well visible, also during daylight hours, for example by using fluorescent clothing.

- Be aware of other road users to whom your wheelchair may be an obstacle. Pay special attention during turning and reversing. If you are not acquainted with how to drive backwards, first practice in an open area. Indicate the direction you are intending to go before turning.
- Try to drive straight in small passages to prevent getting trapped.
- Keep the braking distance in mind. Be aware that the braking distance depends on speed, surface, weather conditions, slope and weight of the user.

3.2.1 Cope with slopes, kerbs, obstacles or ramps

 CAUTION Risk of injuries by unexpected movement

- Use a restraining safety belt to secure yourself sitting in the wheelchair.
 - Pay attention if the road is sandy, has soft ground, holes or gaps that may cause entrapment of the wheels and/or decreasing of the traction of the driving wheels.
 - Do NOT drive on slopes, obstacles, steps or kerbs larger than the size described in the technical specifications in chapter 5.
 - Always approach a kerb from the front.
 - Do not put your wheelchair in free-wheel mode on a slope. The wheelchair may start moving, causing injuries to you or bystanders.
 - Do not use your wheelchair on an escalator or stairs.
 - Only use ramps approved by Vermeiren and do not exceed their maximum load.
- i** When you stop on a slope, the brake will work automatically to prevent the wheelchair from running forward or backward.

CAUTION Risk of damage

- Always park your electric wheelchair on horizontal flat surfaces and on sites that are easily accessible.
- If necessary, take a short run-up to speed up the wheelchair to mount a slope, obstacle, kerb or ramp. Prevent that you or your wheelchair has to cope with a large recoil.
- Make sure that the wheelchair does not touch the ground or ramp due to the inclination of the wheelchair.
- Be aware that the braking distance on downhill slopes can be significantly larger than on level ground.

Procedure

- Start your drive according to the instructions in §3.1, step 1.
- To move the wheelchair up or down stairs/steps, use lifting equipment or a ramp. If these are not available, it can be lifted manually by at least two persons, grasping the frame firmly with both hands. Do not use the backrest, footplate(s), armrests, or wheels to grasp the wheelchair.
- To cope with obstacles or inclinations:
 1. Adjust the wheelchair to its most stable position, see § 3.5.
 2. Drive as slow as possible to cope with the obstacle or inclination.

3.3 Operating console

 CAUTION Risk of injuries or damage

- Be aware that the stability decreases when the wheelchair is adjusted from sitting-straight to inclined position.
 - Make sure there is enough space around the wheelchair to operate backrest and seat.
- i** How to use the operating console is described in a specific user manual, enclosed with the delivery of your wheelchair. If this manual is missing, contact your specialist dealer immediately.

Put the joystick in the neutral (central) position before pressing the on/off button, otherwise the electronics will be blocked. To release this block, switch the operating console off and on again.

Technical protections

The operating console enables you to control all driving components and motors to adjust your body position. For your own safety, and to prevent that the wheelchair gets damaged, movements are monitored by the electronics. This may result in block of movement, speed decrease or complete stop. Consult the user manual of the operating console for more information.

To avoid accidental battery run down, your wheelchair is equipped with an automatic power shutdown system. This system switches off the operating console automatically when it is not operated for a while. If this occurs, simply switch your console back on.

3.4 Brake and free-wheel lever

 CAUTION Risk of injuries or damage

- Only operate the free-wheel lever when your wheelchair is turned OFF. An attendant should operate the free-wheel lever. NEVER operate it from sitting position.
- Do not use the free-wheel mode on slopes and inclinations, see symbol on motor: 

i Make sure that the free-wheel lever is in its braking position BEFORE switching the wheelchair ON. Electromagnetic brakes do NOT function if the wheelchair is in free-wheel mode. This is indicated on the operating console. Driving is not possible.

Your wheelchair is equipped with electromagnetic brakes. The working of the brakes depends on the position of the free-wheel lever (1).

The EM brakes function automatically, **only if** free-wheel lever (1) is in braking position. In this situation, the brakes start braking if:

- the wheelchair is OFF;
- the wheelchair is ON and the joystick is released.

Releasing the joystick makes the wheelchair stop gently and activates the brakes.

Operation of free-wheel lever:



- Turn levers to the “Neutral” symbol to put the wheelchair in free-wheel mode. The motor is now disconnected. The wheelchair can be moved manually.



- Turn levers to the “Drive” symbol to connect the motor to the drive. This should be done before starting the wheelchair.

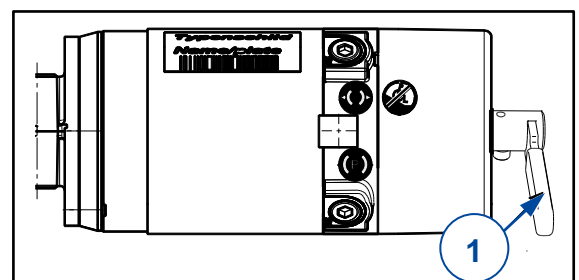

3.5 Moving to/from wheelchair

 CAUTION Risk of injuries or damage

- In case you cannot perform the transfer in a safe manner, ask someone to assist you.
- Do not stand on the footplate(s) during transfer into or out of the wheelchair.

Transfer

1. Position the wheelchair as close as possible to you when sitting in your chair, couch, seat or bed.
2. Apply the brakes by turning the free-wheel lever to braking position, see § 3.4.

3. Use the operating console to move the backrest and seat to sitting position, see user manual of the console.
4. Fold the footplate(s) upwards to prevent standing on them and fold away the knee support.
5. If necessary, swing away one armrest upwards/to the back to make room, see §3.6.2.
6. Transfer to/from the wheelchair using the strength of your arms or with the help of attendant(s) or lifting equipment.

Sitting in the wheelchair

1. Sit down on the seat with your lower back against the backrest.
2. Turn the footplate(s) down and put your feet on the footplates. Turn the knee support into place.
3. Swing down the armrest, if applicable.
4. Make sure that your upper legs are horizontal and that your feet are in a comfortable position. Adjust if necessary.
5. Make sure that your arms are bent and are resting comfortably on the arm pads. Adjust if necessary.

Adjusting to stable position

For transport purposes and when you need to negotiate obstacles, the wheelchair must be adjusted to maximise its stability:

- Seat in horizontal position
- Backrest upright
- Armrests in bottom position
- Footplate folded up or adjusted to a higher position to prevent touching the obstacle
- Operating console turned inwards

3.6 Comfort adjustments

 CAUTION Risk of injuries or damage

- The following comfort adjustments can be done by the attendant or caretaker. All other adjustments are done by your specialist dealer according to the installation instructions, see preface.
- Make sure that your fingers, clothes, buckles don't get trapped during adjustment.

3.6.1 Operating control

The operator console has a swivel system and can be turned horizontally to the left/right.

- Grab the control support (2) below the operator console and move it left/right to the desired position.



3.6.2 Armrests

Position

The armrests can be turned backwards (up) to make it easier to transfer to/from the seat.

1. Push lever (3) of the toothed clamp (4) slowly down. The armrest is unlocked (in bottom position).
2. Turn the armrest up/backwards to its end position.
3. Pull lever (3) up to close the toothed clamp. The armrest is locked in end position.

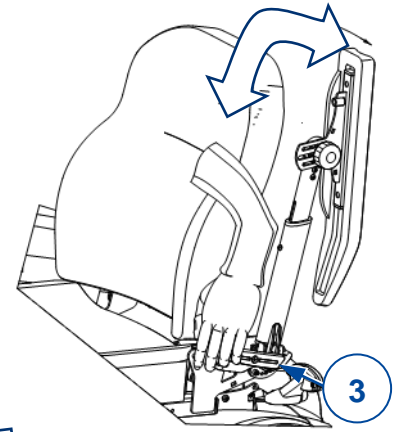

Angle

The same procedure is used to change the angle of the armrest:

1. Repeat previous step 1.
2. Next, hold the armrest in the desired position, while locking it with the lever (3).
3. Repeat this for the second armrest.
4. Make sure that both armrests have the same angle.
5. Make sure that both armrests are firmly secured.

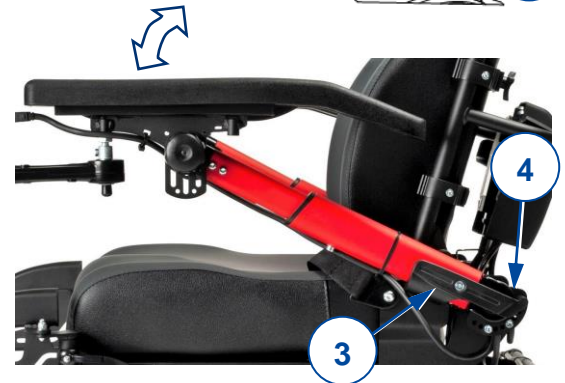

3.6.3 Arm pads

The arm pads (5) can be adjusted in height (stepless, 30 mm) and angle (steps of 7,5°):

1. Turn the star knob (6) a few turns anticlockwise. To adjust the angle, turn it four turns minimally.
2. Pull/push the arm pad lightly to adjust the height.
3. Hold the arm pad at the desired angle.
4. Turn the star knob clockwise until it is finger-tight.
5. Repeat this for the second arm pad.
6. Make sure that both arm pads are firmly secured.



3.6.4 Chest belt



CAUTION

Risk of injury

- Attach the chest belt in such a way that the upper body is pressed against the back section, so that the upper body cannot move involuntarily.
- The chest belt should not restrain the user's arms.
- As using the chest belt can restrict breathing, the patient must agree to the use of the chest belt.

A chest belt is attached to the upper part of the back frame to secure the user during the standing/upright function. Place the chest belt straps on top of one another and press them tightly. The chest belt is made secure by an adhesive system.

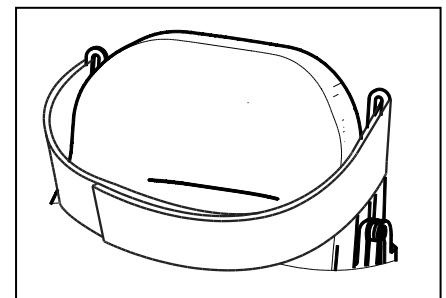

3.6.5 Backrest height



To adjust the height of the backrest (stepless, range of 110 mm):

1. Loosen the 4 star knobs (7).
2. Slide the backrest up/down until the desired position.
3. Retighten the star knobs. Make sure that the backrest is well secured.

Optional side pelots are not compatible with the lower position of the backrest.

3.7 Standing / upright function

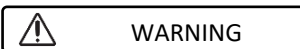

WARNING

Risk of injury

- The standing/upright function may only be used when someone is supervising.
 - The standing/upright function may not be used unless the chest belt and knee protector have been secured. The manufacturer accepts no liability for use of the standing/upright function without the chest belt and knee protector.
 - The standing/upright function may only be used if all four of the wheelchair's wheels are in contact with a level surface (and while being used on the two support wheels).
 - Make sure that no objects, persons or body parts are inside the movement range of the upright function.
 - Ensure that the steering cables do not get caught during the upright function, as this could damage the product.
 - Driving should only take place in the seated position. The drive program should not be used during the standing / upright function. Reduced drive should be deployed only for altering position during the standing / upright function.
 - Only loosen the chest belt and the knee protector again when the wheelchair has been returned to the seated position.
- i** Navix SU has been programmed with some added constraints to ensure your safety:
- Driving at full speed is only possible when the leg rests are positioned at an angle of more than 6°. To prevent damage to the leg rests or support wheels, the speed is automatically lowered when the leg rests are positioned at a lower angle.
 - Adjusting to the standing/upright position is only possible when the leg rests/backrest are adjusted to standard seating position. In case the backrest has been inclined, or the leg rests have been lowered, the seat can only be raised until it forms an angle of 180° with the leg rests/backrest to prevent injury.
 - It is not possible to raise the leg rests when the seat has been raised (in preparation for the standing/upright position).

Follow this sequence when using the standing/upright function:

1. Adjust to the position you want.
2. Ensure that the wheelchair is stable. If necessary, move it to the position you want.
3. Switch off the drive electronics.
4. Deploy the knee protector (or have it deployed for you).
5. Check that the feet are resting flat on the footplate.
6. Deploy the chest belt (or have it deployed for you).
7. Check whether the armrests are in a good position.
8. Switch on the drive electronics and select the adjust function for the upright function.
9. Pull the joystick backwards or push it forwards to carry out the relevant function.

Bear in mind that, when the upright function is in use, the wheelchair rests on the support wheels beneath the footplate. The front wheels lift approx. 10 mm from the ground. To change direction, the wheelchair is then moved using the support wheels and the rear wheels. There is only limited drive functionality.

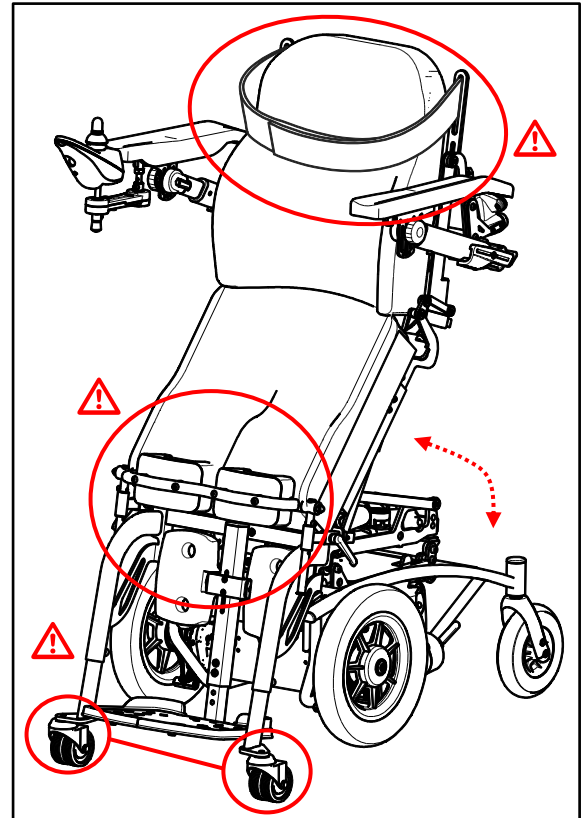

3.8 Battery status and charging

 **WARNING** Risk of injuries and damage due to fire

- Only use the battery charger delivered with the wheelchair. The use of any other charger may be dangerous (fire hazard).
- The battery charger is only intended to charge the batteries delivered with the wheelchair, not to charge any other batteries.
- Do not adapt any of the delivered parts, like cables, plugs or battery charger. Never open or change the battery or the connection points.
- Protect the battery and battery charger against flames, high and low temperatures (see chapter 5), moisture, sunshine, severe shocks (for example dropping). Do NOT use the battery if this has been the case.
- Charge the battery with the battery charger, indoors, in a well-ventilated area, out of children's reach.
- First read the user instruction of the applied battery charger before charging the wheelchair's battery. For more information, contact your specialist dealer or consult our website <http://www.vermeiren.com/>

 **CAUTION** Risk of damage

- Battery self-discharge and the quiescent current of the connected users will drain the battery charge slowly. The battery may be irreversibly damaged if the battery is fully discharged. Therefore, make sure that the battery is charged on time (see manual of operating console).
- Read the storage and maintenance instructions in chapter 4 and technical details in chapter 5.
- Only disconnect the battery charger when the battery is fully charged.
- Do not charge batteries below 0°C. Move the battery to a warmer place and start charging.
- Keep the connection point for the battery charger free of dust and other contamination.

- In case of any problems whereby the battery cannot be charged according to following instructions, please contact your specialist dealer.
- For instructions on how to change the batteries, see the installation manual.

For all information on battery status indication, please read the manual of the operating console.

- i** It is recommended to unplug the battery charger from the mains when not in use. This is to prevent unnecessary energy consumption.

To charge the battery:

1. FIRST connect the battery charger to a 230V AC power socket. Use the battery charger directly, without extension cord, on the power supply (without time switch).
2. Plug the adapter in the charging point of the operating console.
3. Wait until the battery is fully charged. Consult the battery charger manual for more information.
4. Disconnect the battery charger.
5. Remove the battery charger from the socket, let it cool down and store it in the charger pocket.

3.9 Anti-tipping (B78)

 CAUTION Risk of injury

Check that the anti-tipping is working before driving with the electric wheelchair.

For your safety, your electric wheelchair is equipped with an anti-tipping  that works with a suspension system. When crossing small obstacles (no higher than 70 mm), this system tips back a little, yet overtipping is prevented by a stopping mechanism. Do not remove the anti-tipping device as your wheelchair will no longer be secured against accidentally tipping over.

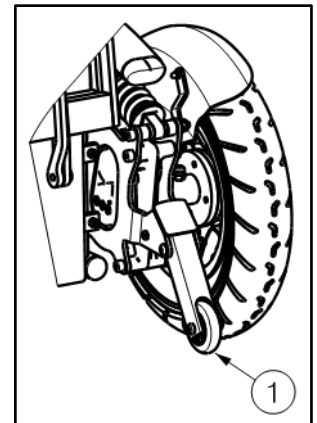

4 Maintenance

4.1 Time of maintenance

 CAUTION Risk of injuries and damage

Repairs and replacements may only be undertaken by trained persons and only genuine replacement parts of Vermeiren should be used (see the maintenance manual).

i The last page of this manual contains a registration form for the specialist dealer to record each service.

The service frequency depends on the frequency and intensity of use. Contact your dealer to agree to a common timetable for inspection/maintenance/repair.

Read the user instructions of the applied battery charger regarding maintenance.

For the maintenance manual, refer to the Vermeiren website: www.vermeiren.com.

Before each use

Inspect the following points:

- All parts: present and undamaged or worn.
- All parts: clean, see § 4.2.2.
- Wheels, seat, calf rests, arm rests, footplate and headrest (if applied): well secured.
- Battery status: charge the battery when necessary, see §3.8.
- Operating console, battery, power module, motors, battery charger, lights and relevant cables: no damage such as wires that have become frayed, broken or exposed.
- Condition of wheels/tyres, see § 4.2.1.
- Condition of frame parts: no deformation, instability, weakness or loose connections.
- Seat, backrest, arm pads, calf pads and head rest (if applied): no excessive wear (like dented spots, damage or tears).

Contact your specialist dealer for possible repairs or part replacements.

Every month

If your wheelchair is stored for a longer period, you still need to charge the batteries every month. It is also possible to keep the battery charger connected to the battery and the mains during this period. For more information, see §3.8.

Yearly or more often

Have your wheelchair inspected and serviced by your specialist dealer, at least once a year, or more often. The minimum maintenance frequency depends on use and should therefore be commonly agreed upon with your specialist dealer.

If stored

Make sure that your wheelchair is stored in a dry environment to prevent mould from growing, or the upholstery from being damaged.

4.2 Instructions for maintenance

4.2.1 Wheels and tyres

i Proper working of the brakes depends on the state of the tyres, that can change due to wear and contamination (water, oil, mud, ...).

- Keep your wheels free of wires, hair, sand and fibres.
- Check the profile of the tyres. If the tread depth is less than 1 mm, the tyres need to be replaced. Contact your specialist dealer for this matter.
- Inflate the pneumatic tyres to the correct pressure (see pressure indication on the tyres).
- For instructions on how to change the tyres, see the installation manual.

4.2.2 Cleaning

CAUTION

Risk of damage by moisture

- Keep the operating console clean and protect it from water and rain.
- Never use a hose or high-pressure cleaner to clean the wheelchair.

Wipe all rigid parts of the wheelchair with a damp cloth (not drenched). If necessary, use a mild soap, suitable for varnishes and synthetics.

The upholstery can be cleaned with lukewarm water and a mild soap. Do not use abrasive cleaning agents to clean.

Keep the ventilation openings of the battery charger clean and free of accumulated dust. Blow away the dust and clean the battery charger enclosure with a slightly moistened cloth, if required.

4.2.3 Disinfection

CAUTION

Risk of damage

Disinfections may only be undertaken by trained persons. Consult your specialist dealer.

4.3 Troubleshooting

Even if you use your wheelchair properly, a technical problem may occur despite this. In this case, contact your local specialist dealer.



WARNING

Risk of injuries and damage to the wheelchair

- NEVER attempt to repair your wheelchair yourself.
- For failures in the operating console you need to contact your specialist dealer. He/She will decide if the console needs to be reprogrammed.

In case of failure, a fault code is displayed on the operating console.

- i** For an overview of all fault codes on the operating console, please read the manual of the operating console.

The following symptoms may indicate a serious problem. Therefore, always contact your specialist dealer if you spot any of the following deviations:

- Strange sound;
- Frayed/damaged wiring harnesses;
- Cracked or broken connectors;
- Uneven tread wear at one of the tyres;
- Jerky movements;
- Wheelchair deflects to one side;
- Damaged or broken wheel assemblies;
- Wheelchair does not switch on (blown fuse);
- Wheelchair is powered but does not move, see 4.3.1.

4.3.1 Overload protection

To protect the motor against overload, the motor is automatically cut off in the following situations:

- driving up or down slopes that exceed the maximum gradient indicated in chapter 5.
- the nominal load exceeds its upper limit.

To use the wheelchair again: place joystick in neutral, remove the overload and wait until the motor has cooled down.

4.4 Expected lifespan

The average lifespan of your wheelchair is 5 years. Depending on the frequency of use, driving circumstances and maintenance, the lifespan of your wheelchair will increase or decrease.

4.5 Reuse

Before each reuse, have the wheelchair disinfected, inspected and serviced according to the instructions in §4.1 and §4.2.

4.6 End of use

At end of life, you need to dispose of your wheelchair according to the local environmental legislation. The best way to do so, is to disassemble the wheelchair to facilitate the transport of recyclable parts.

5 Technical specifications

The technical details below are only valid for this wheelchair, at standard settings and optimal ambient conditions. Take these details into account during use.

The values are no longer applicable if your wheelchair has been modified, damaged, or is severely worn. Be aware that the driving performance is influenced by ambient temperature, humidity, slopes (driving up/down), type of surface and battery status.

Table 1: Technical specifications

Brand	Vermeiren
Type	Electric wheelchair, Class A
Model	Navix SU
Maximum occupant mass	130 kg

Description	Dimensions	
Effective seat width	400 mm 450 mm	
Overall width (depends on the width of the armrests: minimum)	602 mm 670 mm	
Description	Dimensions Minimum	Dimensions Maximum
Max. speed (limited in standing position)	6 km/h	
Continuous driving distance range*	Approx. 20 km (38Ah) Approx. 32 km (50Ah)	
Overall length (with footplate lowered, not folded up)	1090 mm	
Overall height (sitting position)	1040 mm	
Overall height (standing position)	1570 mm	
Folded / dismantled length (footrests removed)	Not applicable	
Folded / dismantled width	Not applicable	
Folded / dismantled height	Not applicable	
Total mass	122 kg	
Mass of heaviest part (that can be dismantled or removed)	Not applicable	
Masses of parts that can be dismantled or removed.	Not applicable	
Maximum safe slope	9°	
Obstacle climbing	50 mm	
Ground clearance	60 mm	
Seat plane angle	3,5°	-84,5°
Effective seat depth	395 mm	470 mm
Thickness seat cushion	70 mm	
Seat surface height at front edge (without seat cushion)	470 mm	
Backrest angle	Seat width 40: 11° - 30° Seat width 45: 11° - 84°	
Backrest height	510 - 620 mm	
Distance between footplate and seat	365 mm	465 mm
Angle between seat and leg footplate	0°	96,5°
Angle between footplate and leg footplate	90°	
Distance between armpad and seat	242 mm	350 mm

Brand	Vermeiren
Type	Electric wheelchair, Class A
Model	Navix SU
Maximum occupant mass	130 kg

Front location of armrest structure	508 mm	557 mm
Armrest Angle	11°	26° / 101° (folded away)
Height legrests to top of seat (measured in the middle of the cushion)	155 mm	210 mm
Height footplate to knee support (measured in the middle of the cushion; length footplate minimum position)	400 mm	460 mm
Depth knee support and legrests	60 mm	120 mm
Driving motors	2 x 220W + electromagnetic braking system	
Batteries	2 x 12V --- AGM / 38 Ah or 50 Ah / 20 hr	
Blow fuse	150 AMP	
Degree of protection	IPX4	
Minimum turning diameter	Approx. 1250 mm	
Reversing width	1250 mm	
Diameter Rear wheels (number)	200 x 50 mm (2)	
Tyre pressure, rear wheels **	Max. 2.5 bar	
Diameter front wheels (number)	317.5 x 57.15 mm air (2)	
Tyre pressure, front wheels **	Max. 2.5 bar	
Noise level	< 65 dB (A)	
Strength tests according to	ISO 7176-8	
Tests of power and control system according to	ISO 7176-14	
Ignitability of upholstery according to	EN1021-2:2006	
EMC compliance	ISO 7176-21	
Storage and use temperature	+5 °C to +41 °C	
Operating temperature of the electronics	-10°C to +40°C	
Storage and use humidity	30%	70%

We reserve the right to introduce technical changes. Measurement tolerance ± 15 mm / 1,5 kg / 1,5°.

*** The theoretical driving distance will be reduced if the wheelchair is used frequently on slopes, rough ground or to climb curbs.**

****Since different tyres may be used, please note the correct operating pressure of the tyres you use.**

**Service registration form**

This product (name):

was inspected (I), serviced (S), repaired (R) or disinfected (D):

By (stamp): Kind of work: I / S / R / D Date:	By (stamp): Kind of work: I / S / R / D Date:	By (stamp): Kind of work: I / S / R / D Date:
By (stamp): Kind of work: I / S / R / D Date:	By (stamp): Kind of work: I / S / R / D Date:	By (stamp): Kind of work: I / S / R / D Date:
By (stamp): Kind of work: I / S / R / D Date:	By (stamp): Kind of work: I / S / R / D Date:	By (stamp): Kind of work: I / S / R / D Date:
By (stamp): Kind of work: I / S / R / D Date:	By (stamp): Kind of work: I / S / R / D Date:	By (stamp): Kind of work: I / S / R / D Date:
By (stamp): Kind of work: I / S / R / D Date:	By (stamp): Kind of work: I / S / R / D Date:	By (stamp): Kind of work: I / S / R / D Date:



Vermeiren GROUP
Vermeirenplein 1 / 15
2920 Kalmthout
BE

website: www.vermeiren.com

Instructions for specialist dealer

This instruction manual is part and parcel of the product and must accompany every product sold.

Version: E, 2022-04

Basic UDI: 5415174 122127Navix SU LG

All rights reserved, including translation.

VERMEIREN
we care for you